

NXS Series

Ultra-High Density, Space Qualified Interconnect

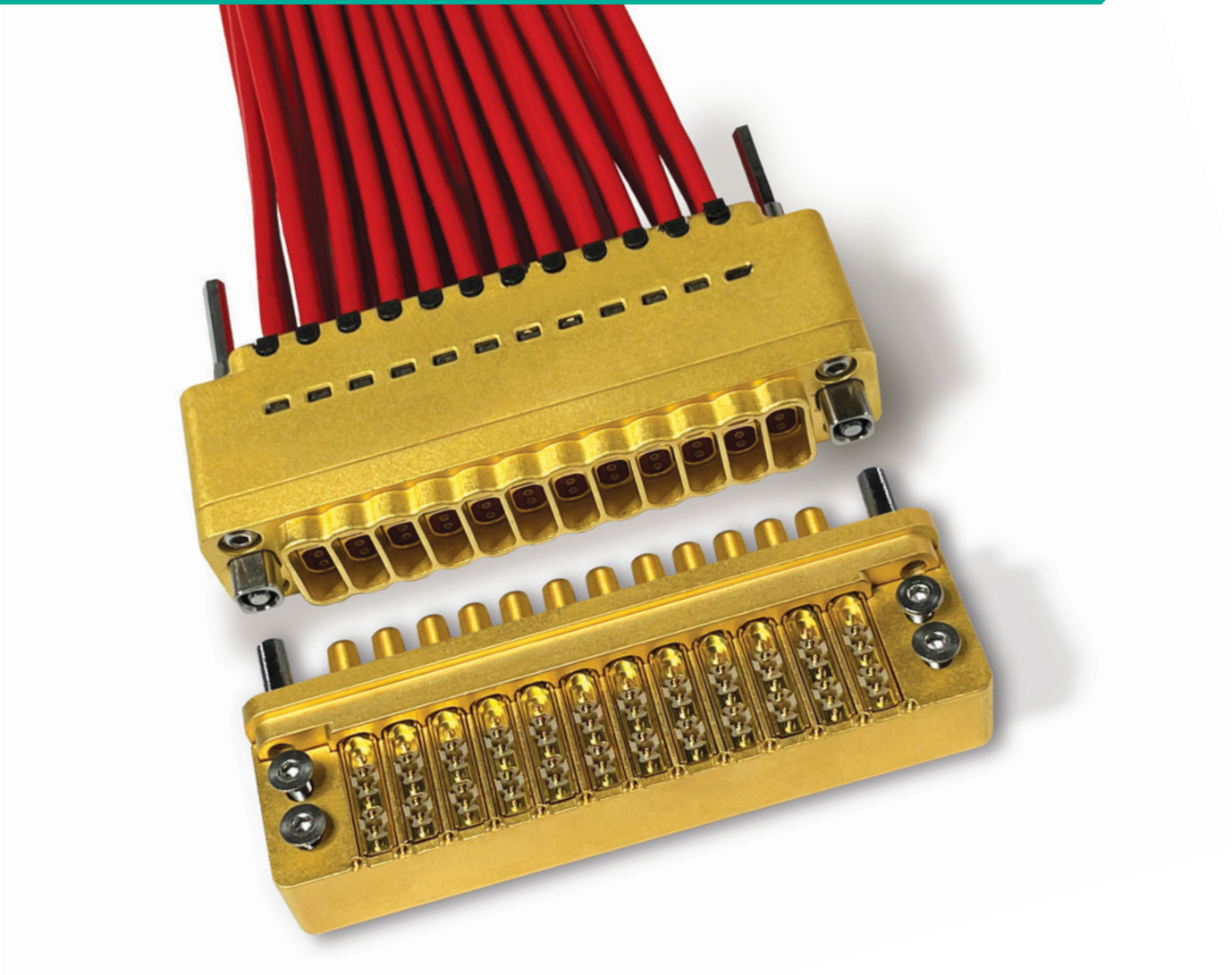

NXS Series

Ultra-High Density, Space Qualified Interconnect

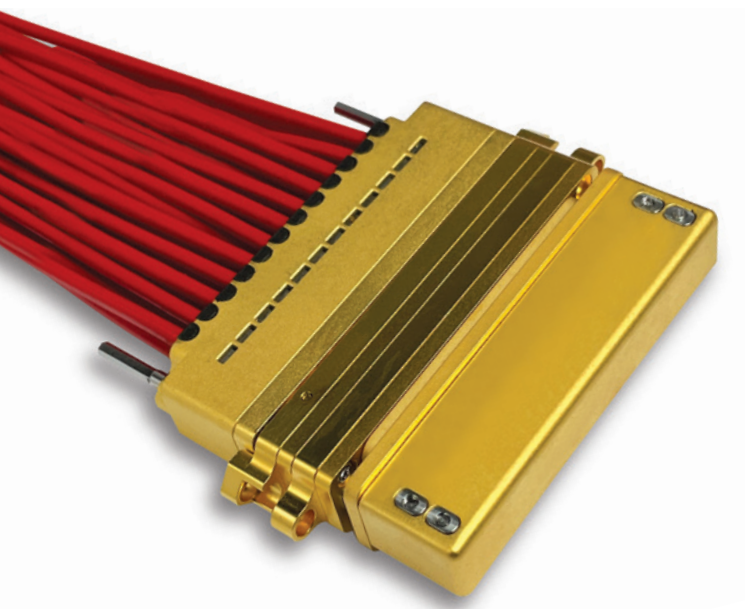

Today, space satellites are moving away from RF Analog based payloads providing low speed telecommunication signaling, to a new Digital Transparent Processor architecture for high throughput satellites. Those architectures increase the demand for rugged and higher speed connectivity.

To meet those industry needs, Smiths Interconnect has developed the NXS Series, an advanced high speed, high density interconnect to provide next generation data on demand.

Equipped with the Hypertac® hyperboloid contact technology the NXS system can withstand data rate application up to 10 Gbps (per channel) requirements, including extreme levels of vibration, shock and climatic testing above 2100 G. The NXS Series is designed in a robust construction with 4 or 12 high speed quadrax (dual-twinax) modules.

Each ultra-high density quadrax module contains 2 dual twinax at 100 Ω each pair. It is blind mateable, hot pluggable, with ultra-low mating forces and low outgassing materials.

In addition, the solderless PCB mount design reduces the customer's risk and cost of ownership. The connector is mounted after reflow and has no impact on nearby components. Each product is engineered using 3D electromagnetic simulation (EM) software to provide excellent performance in a total thin film process.

Specifically designed and tested for High Speed Space applications up to 10 Gbps per channel.

Features

- Low outgassing materials
- Hyperboloid contact technology
- Solderless PCB Termination
- 4 and 12 bay configurations

Benefits

- Weight savings
- Ultra high contact density
- Ultra low mating force
- Withstands high shock and vibration space environments

Designed to exceed the requirements of:

- ESCC 3401
- ESCC 3402
- ECSS-Q-ST-70C
- ECSS-Q-ST-70-02
- ECSS-Q-ST-70-08C
- ECSS-Q-ST-70-38C
- ECSS-Q-70-71

Technical Characteristics

Materials and Finish

	Materials and Finish
Connector Plug/Receptacle Shells	Composite – (base material: PEEK 30% carbon filled) Finish: Gold over nickel
Inner Shell (Quad module)	Aluminium alloy Finish: Gold over nickel
Saver Shells	Aluminium alloy Finish: Gold over nickel
Contacts	Copper alloy Finish: Gold over nickel
Insulators/Dielectric	PEEK
Guide Hardware	Stainless steel and titanium alloy
Fasteners	Stainless steel

Specification

Parameter	Level
Working Voltage	50 V RMS
Current	1 A
Data Transmission Rate	Up to 10 Gbps per channel
Impedance	100 Ω \pm 10%
Contact Resistance	150 m Ω
Insulation Resistance (minimum)	1 G Ω
Operating Temperature Range	-40 °C to 125 °C
Durability (mate/unmate with Saver fitted)	500 cycles

Connector Outline Drawings

NXS Receptacle

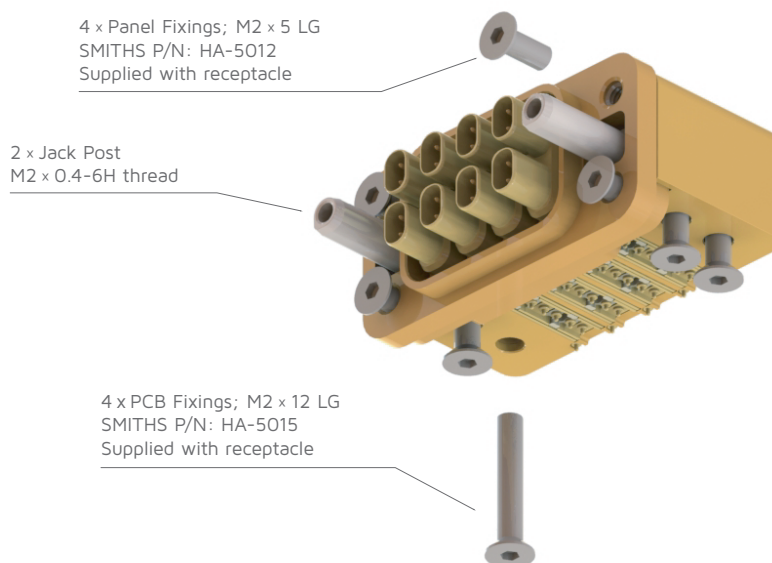
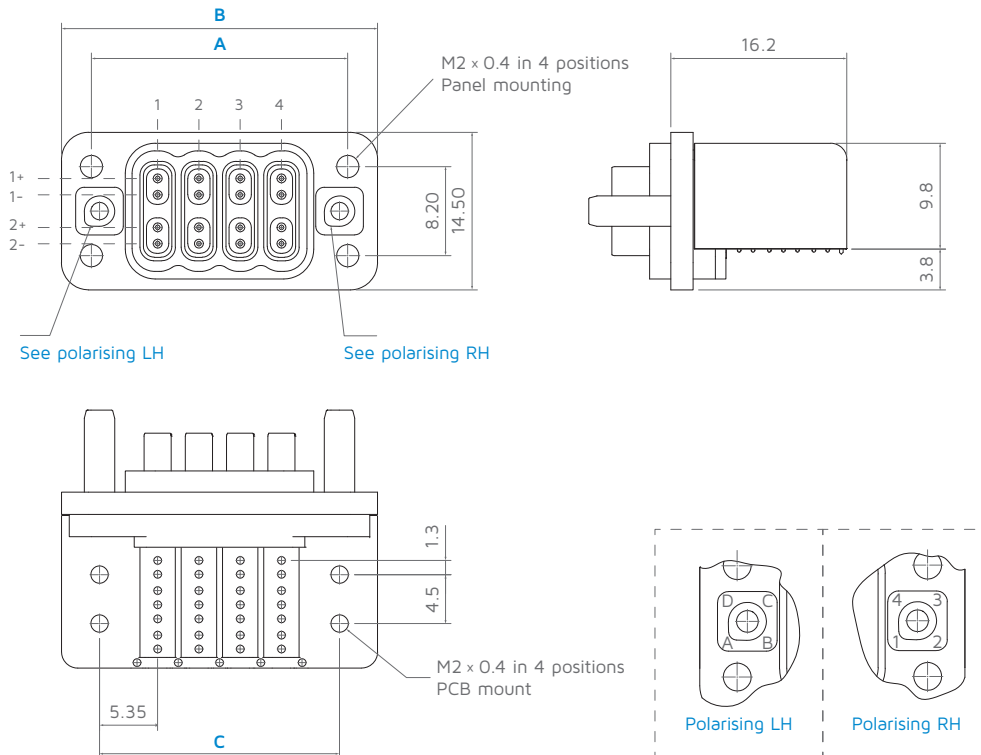

Note

Contacts supplied fitted – each quadrax module contains 2 x 100 Ω differential pair.
Dimensions are in mm.

Recommended PCB Footprint

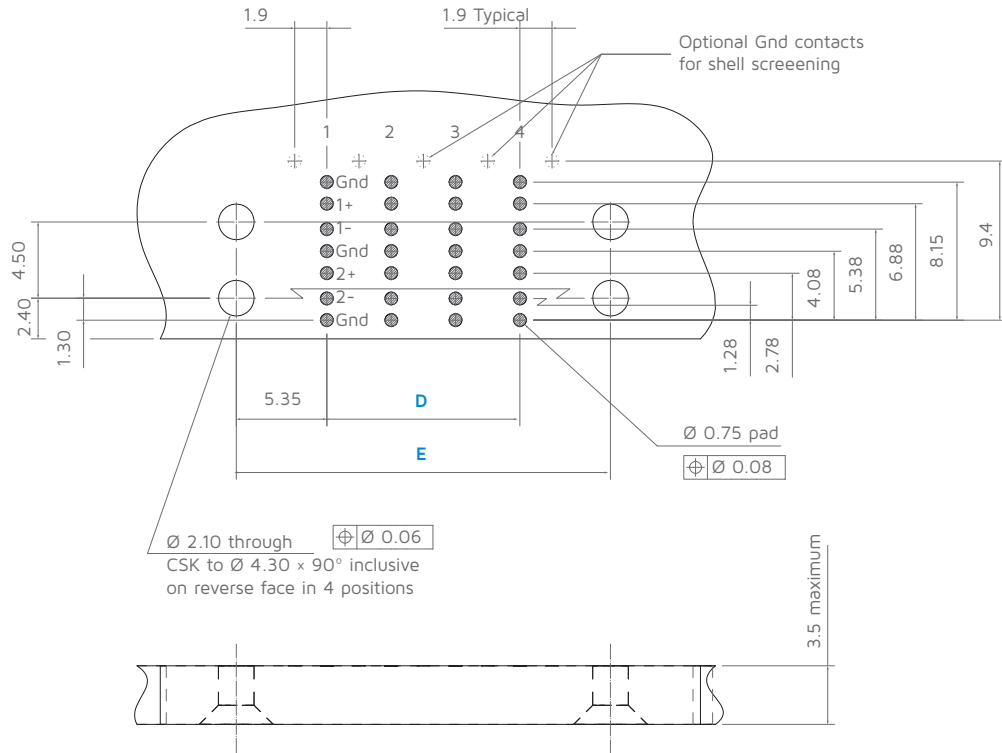

Recommended Panel Cut-out

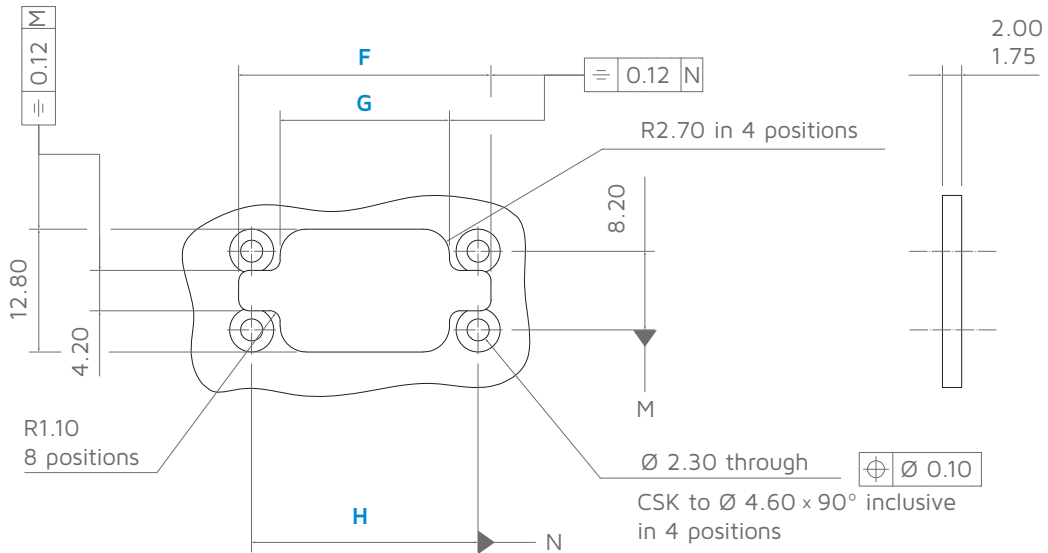

Variable Dimensions

Number of ways	A	B	C	D	E	F	G	H
4	23.6	29.1	22.1	3x3.8 = 11.4	22.1	26.3	17.65	23.6
12	54.0	59.5	52.5	11x3.8 = 41.8	52.5	56.7	48.05	54.0

Dimensions are in mm.

NXS Plug

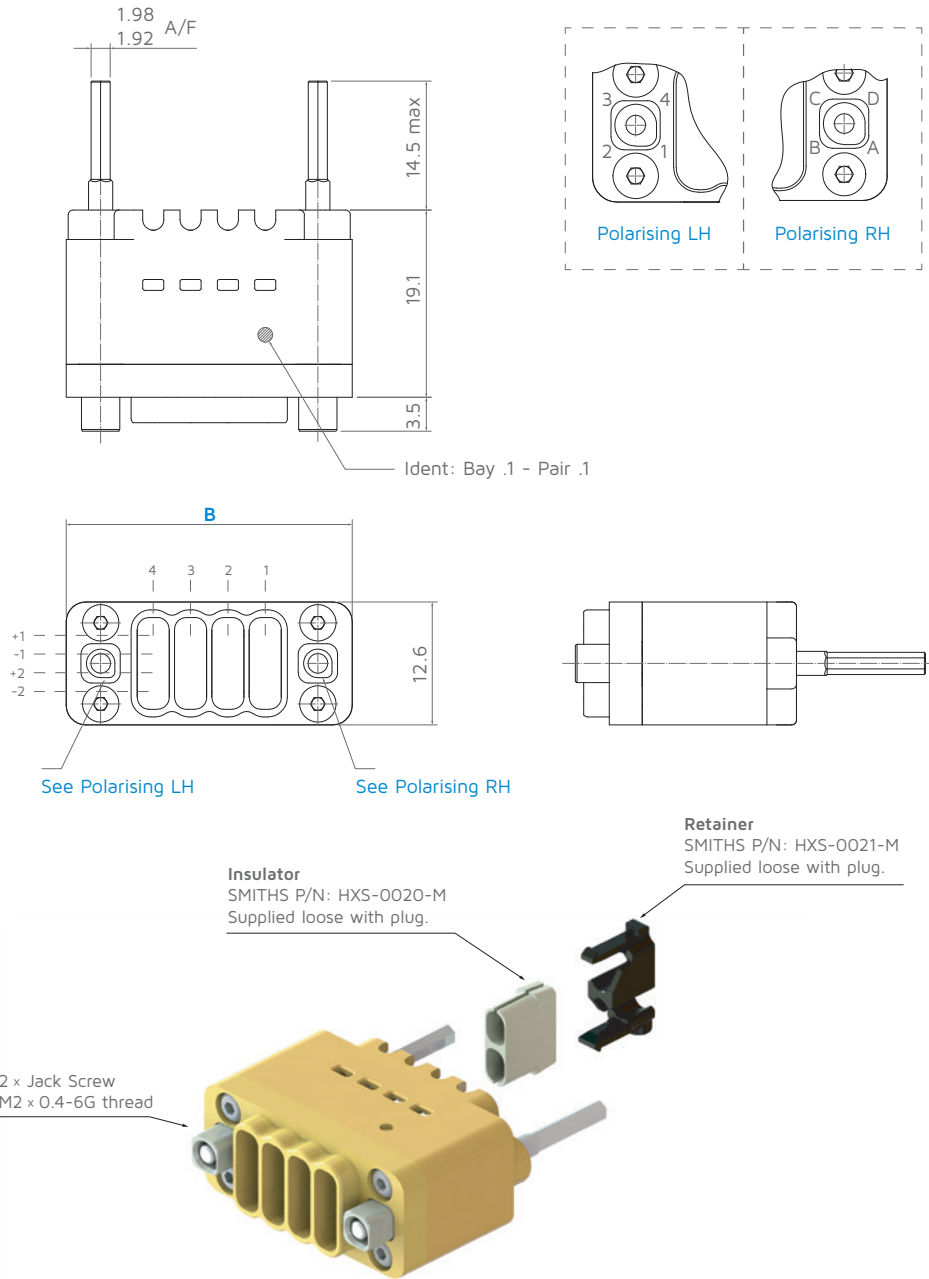

Variable Dimensions

Number of ways	A	B	C
4	-	29.2	-
12	-	59.6	-

Note

- Plug is supplied with relevant 'support insulators' and 'retention clips' for recommended cable.
- For cable termination details, please refer to "Accessories", on page 9.
- Recommended cable (100 Ω differential, 50 Ω signal to shield):
 - WL GORE GSC-05-83111-00
 - TENSOLITE 540-1153-000
 - AXON AM526-A07

Dimensions are in mm.

NXS Saver (Plug)

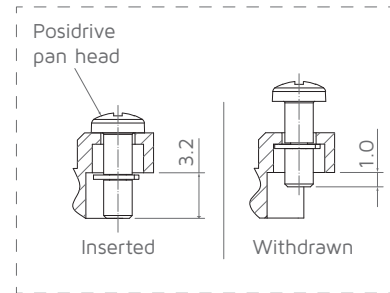
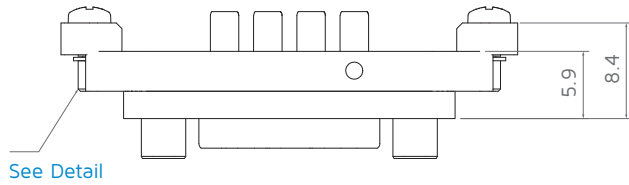

Detail
Showing range of captive fixing

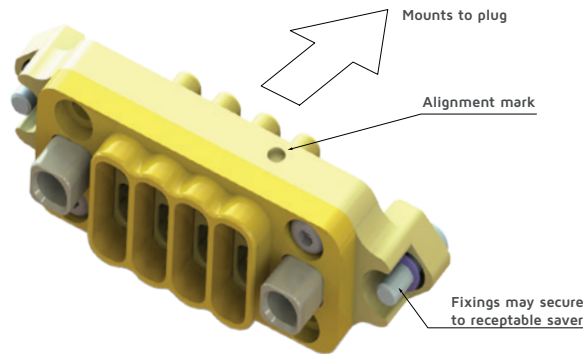
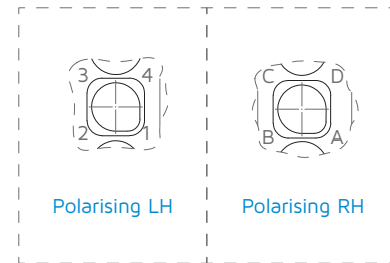
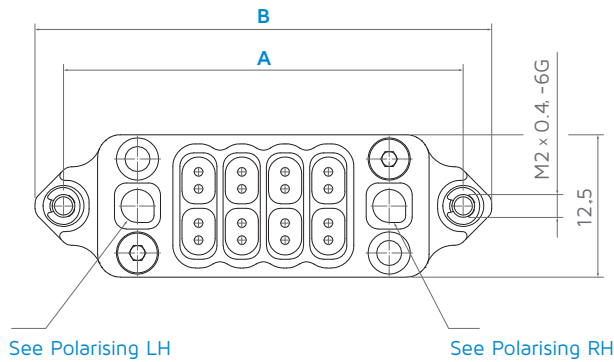

Variable Dimensions

Number of ways	A	B	C
4	35.1	40.1	-
12	65.5	70.5	-

Note

See application guide for mounting details.
Dimensions are in mm.

NXS Saver (Receptacle)

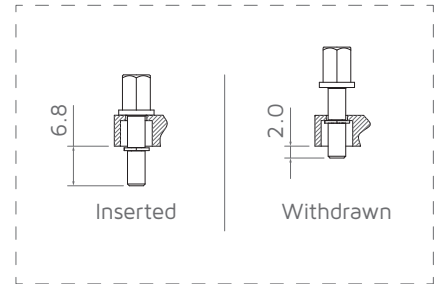
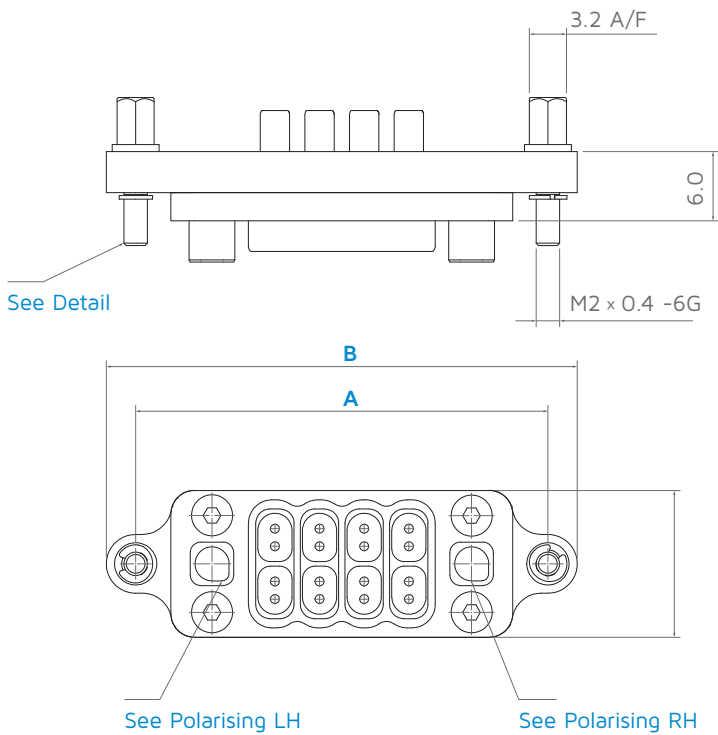

Detail
Showing range of captive fixing

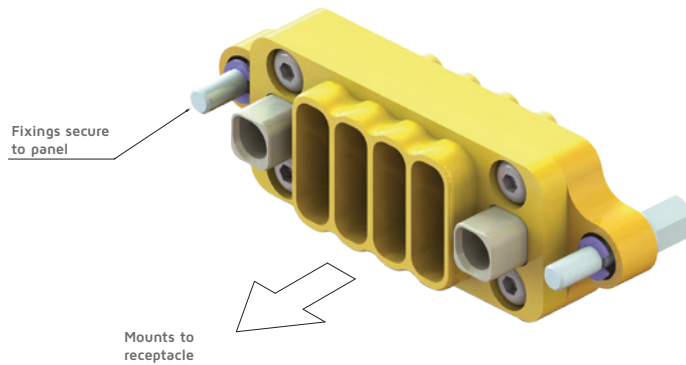
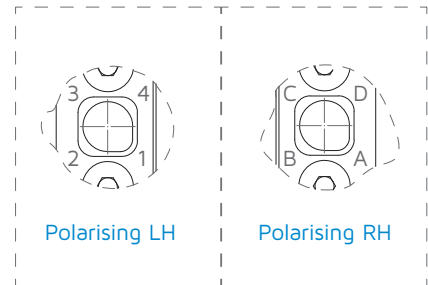

Variable Dimensions

Number of ways	A	B	C
4	35.1	40.1	-
12	65.5	70.5	-

Note

See application guide for mounting details.
Dimensions are in mm.

Accessories

Description	Smiths Interconnect Part Number	
Cavity filler	HXS-0060-107	
Clip, cable retention	HXS-0021-M	
Termination Kit	HXS-7009 Parts may be supplied individually in bulk orders to suit customer stock and build process. See below for breakdown of Kit:	
Contact outer Shell	HYP-7049-H-117 (x2 if supplied in kit)	
Socket Contact	HHSC-0156-100 (x4 if supplied in kit)	
Insulator / Dielectric	HYP-6944-M (x2 if supplied in kit)	
Spacer	HXS-0065 (x4 if supplied in kit)	

Plug Cable Termination

(Twinax – as detailed above)

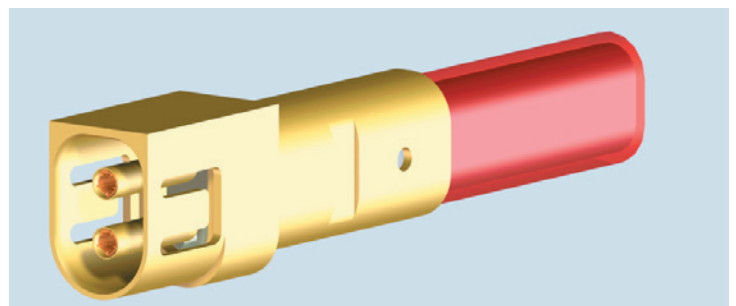
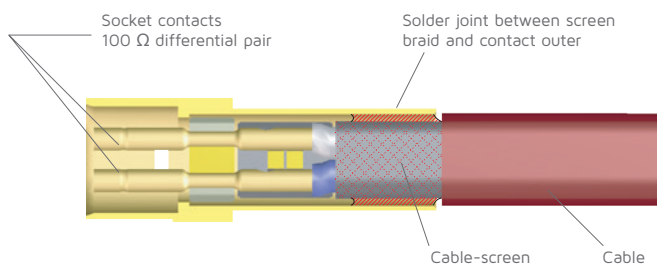

Note

Please refer to Application guide for stripping details.

Disclaimer

All of the information included in this catalogue is believed to be accurate at the time of printing. It is recommended, however, that users should independently evaluate the suitability of each product for their intended application and be sure that each product is properly installed, used and maintained to achieve desired results.

Smiths Interconnect makes no warranties as to the accuracy or completeness of the information, and disclaims any liability regarding its use. Smiths Interconnect reserves the right to modify design and specifications, in order to improve quality, keep pace with technological development or meet specific production requirements.

No reproduction or use without express permission of editorial and pictorial content, in any manner.

Worldwide Support

Connectors

Americas

Sales

connectors.uscsr@smithsinterconnect.com

Technical Support

connectors.ustechsupport@smithsinterconnect.com

Europe

Sales

connectors.emeacsr@smithsinterconnect.com

Technical Support

connectors.emeatechsupport@smithsinterconnect.com

Asia

Sales

asiacsr@smithsinterconnect.com

Technical Support

asiatechsupport@smithsinterconnect.com

Fibre Optics & RF Components

Americas

Sales

focom.uscsr@smithsinterconnect.com

Technical Support

focom.techsupport@smithsinterconnect.com

Europe

Sales

focom.emeacsr@smithsinterconnect.com

Technical Support

focom.techsupport@smithsinterconnect.com

Asia

Sales

focom.asiacsr@smithsinterconnect.com

Technical Support

focom.techsupport@smithsinterconnect.com

Semiconductor Test

Americas

Sales

semi.uscsr@smithsinterconnect.com

Technical Support

semi.techsupport@smithsinterconnect.com

Europe

Sales

semi.emeacsr@smithsinterconnect.com

Technical Support

semi.techsupport@smithsinterconnect.com

Asia

Sales

semi.asiacsr@smithsinterconnect.com

Technical Support

semi.techsupport@smithsinterconnect.com

RF/MW Subsystems

Americas, Europe & Asia

Sales

subsystems.csr@smithsinterconnect.com

Technical Support

subsystems.techsupport@smithsinterconnect.com

Connecting Global Markets

more > [smithsinterconnect.com](https://www.smithsinterconnect.com) | [in](#) [twitter](#) [youtube](#)